

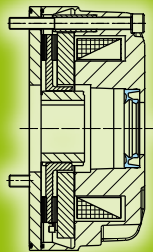

your reliable partner

ROBA[®]-stop[®]-M

Electromagnetic
safety brakes

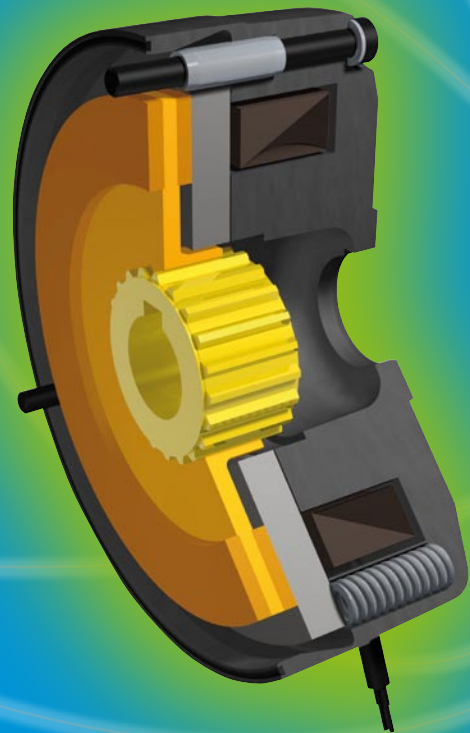

Your Reliable Brake

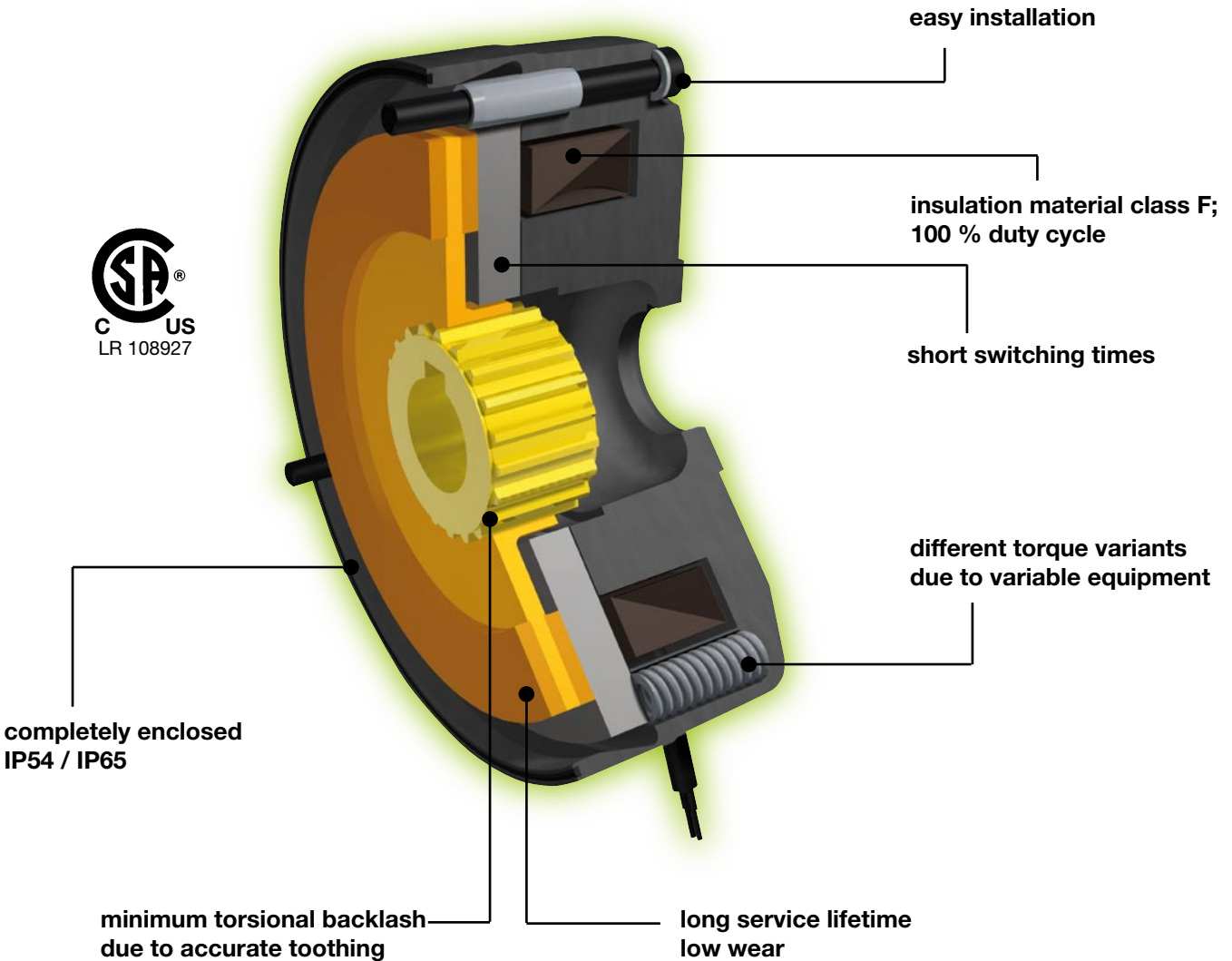

Advantages for Your Applications

- Easy installation
- Brake outer diameter completely enclosed (higher protection can easily be realised)
- Magnetic coil is designed for a relative duty cycle of 100 %
- Magnetic coil and casting compound correspond to insulation material class F
- The nominal air gap is constructionally specified and inspected
- Short switching times
- Maintenance-free for rotor lifetime

Designs and Variants

See Type key on page 3, Dimensions Figs., Technical Data and Dimensions Sheets on pages 4 and 5 and Further Options on page 10.

Function

ROBA-stop[®]-M brakes are spring applied, electromagnetic safety brakes.

Spring applied:

In a de-energised condition, helical springs (6) press against the armature disk (5). The rotor (3) is held between the armature disk (5) and the corresponding mounting surface of the machine. The shaft is braked via the gear hub (1).

Electromagnetic:

When the power is switched on, a magnetic field is built up. The armature disk (5) is attracted to the coil carrier (2) against the spring pressure. The brake is released and the shaft is able to rotate freely.

Safety brakes:

The brake brakes reliably and safely in the event of power switch-off, a power failure or an EMERGENCY STOP.

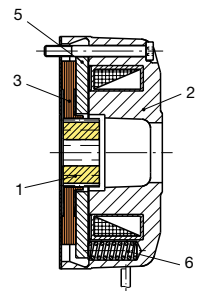

ROBA-stop®-M Page 4 ▷

Sizes 2 up to 1000

Braking torques

0,7 up to 1400 Nm
(Standard brake)

4 up to 1600 Nm
(Holding brake)

Permitted shaft diameters

8 up to 90

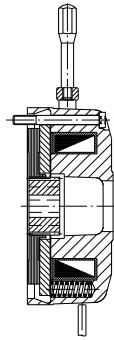

Type 891._11.0 Standard design

Page 5 ▷

Type 891._12.0 Standard design with friction disk

Type 891._14.1 IP65 design with flange plate

Type 891._14.2 Tacho attachment design with flange plate

Short Description Installation Page 6 ▷

Brake Dimensioning, Friction-Power Diagrams Page 8 ▷

Further Options Page 10 ▷

Switching Times, Electrical Connection, Electrical Accessories Page 11 ▷

Guidelines Page 19 ▷

Order Number

| | | | |
|--|---|---|---|
| Nominal torque holding brake | 0 | 0 | Without supplementary parts |
| Nominal torque standard | 1 | 1 | Hand release ¹⁾ |
| 84 % nominal torque ⁶⁾ | 2 | 2 | Friction disk ⁷⁾ |
| 68 % nominal torque ⁶⁾ | 3 | 3 | Hand release/Friction disk ^{1) 7)} |
| 50 % nominal torque ⁶⁾ | 4 | 4 | Flange plate ⁸⁾ |
| 34 % nominal torque ⁶⁾ | 5 | 5 | Hand release/Flange plate ^{1) 8)} |
| Nominal torque adjustable ^{2) 6)} | 6 | | |
| 112 % nominal torque ⁶⁾ | 7 | | |
| 125 % nominal torque ⁶⁾ | 8 | | |

| | | | | | | | |
|------------------------------------|--|-------------|--|------------------|---|---|---|
| _ / 8 9 1 . _ _ . _ / _ / _ / _ | | | | | | | |
| ▲ | ▲ | ▲ | ▲ | ▲ | ▲ | ▲ | |
| Sizes 2 up to 1000 | Standard brake metal rotor ³⁾ Holding brake metal rotor Standard brake Friction lining rotor ⁴⁾ | 0 1 2 | Standard ¹¹⁾ Enclosed design IP65 ⁵⁾ Tacho design ⁵⁾ Central torque adjustment ²⁾ | 0 1 2 3 | Coil voltage ⁹⁾ [VDC] 24 ¹⁰⁾ 104 180 207 | Bore Hub Ø d (please observe dimensions on pages 4-5, Table 2, page 7) | Keyway acc. DIN 6885/1 or DIN 6885/3 |

Example: 16 / 891.211.0 / 24 / 16 / 6885/1 **For Further Options, see page 10.**

- | | |
|---|---|
| <p>1) Hand release not installed on Sizes 2 – 500. Size 1000: hand release only available as emergency hand release. Hand release for IP65 design only ex works.</p> <p>2) On request</p> <p>3) From Size 60</p> <p>4) Up to Size 32 (for brake operation in hoisting device drives, please contact the manufacturer)</p> <p>5) Not in combination with friction disk</p> | <p>6) See Technical Explanations pages 6 – 7</p> <p>7) Sizes 2 – 60</p> <p>8) Standard tacho brake flange plate</p> <p>9) Brake operation only with overexcitation on Size 500 from 700 Nm onwards and on Size 1000.</p> <p>10) Not possible on Size 1000.</p> <p>11) Standard and tacho design are identical on Size 1000. Order number for standard (tacho design) on Size 1000: 1000 / 891._._._2 / _ / _ / _</p> |
|---|---|

 **ROBA-stop®-M brakes are also available in ATEX-design according to the directive 94/9 EC (ATEX 95) (Please contact the manufacturer separately for this).**

 **On request ROBA-stop®-M brakes can also be delivered with UL approval.**

 **According to German notation, decimal points in this document are represented with a comma (e.g. 0,5 instead of 0.5).**

ROBA-stop®-M – electromagnetic safety brakes

Type 891._.1.0

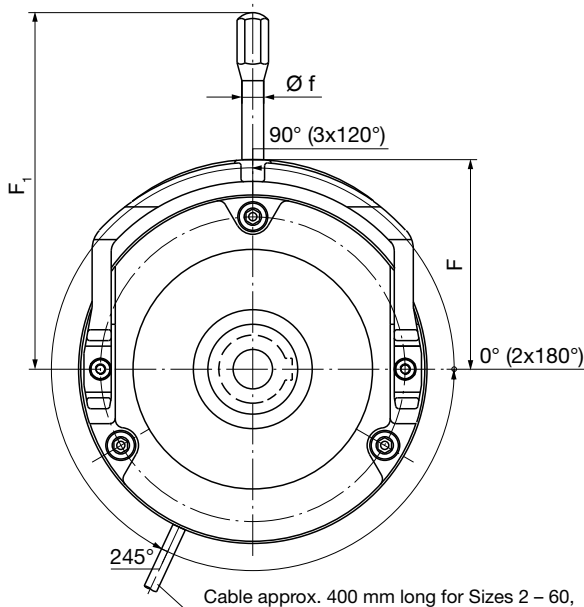

Cable approx. 400 mm long for Sizes 2 – 60,
for Sizes 100 – 500 approx. 600 mm long
for Size 1000 approx. 2000 mm long

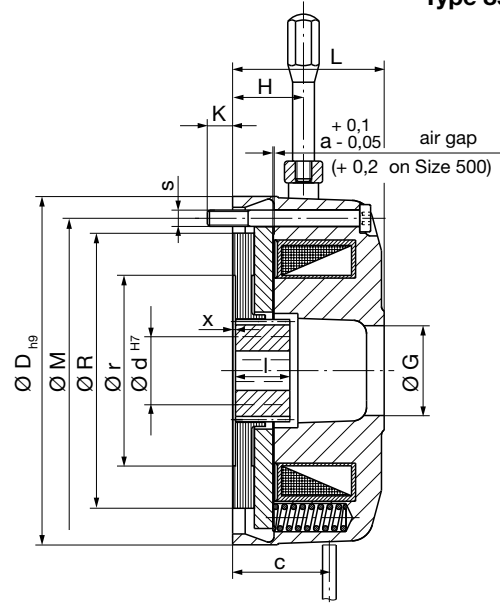

| Technical Data | | | | Size | | | | | | | | | | |
|----------------|--|-----------------|------|------|------|------|------|------|------|------|------|---------------------|-------------------------|------|
| | | | | 2 | 4 | 8 | 16 | 32 | 60 | 100 | 150 | 250 | 500 | 1000 |
| Braking torque | Standard brake ¹⁾ Type 891.0_2_... | M_{nenn} [Nm] | 2 | 4 | 8 | 16 | 32 | 60 | 100 | 150 | 250 | 500 ^{1.2)} | 1000 ^{1.2) 5)} | |
| | Holding brake ^{1.2)} Type 891.1_... | M_{nenn} [Nm] | 4 | 8 | 16 | 32 | 64 | 100 | 180 | 250 | 450 | 800 ³⁾ | 1600 ⁵⁾ | |
| Input power | P_{nenn} [W] | 19 | 25 | 29 | 38 | 46 | 69 | 88 | 98 | 120 | 152 | 160 | | |
| Maximum speed | $n_{max.}$ [rpm] | 6000 | 5000 | 4000 | 3500 | 3000 | 3000 | 3000 | 1500 | 1500 | 1500 | 1500 | | |
| Weight | Standard brake Type 891.0_2_... | m [kg] | 0,76 | 1,1 | 1,8 | 3,4 | 4,5 | 7,4 | 13,6 | 19,2 | 33,3 | 38 | 79 | |
| | Holding brake Type 891.1_... | m [kg] | 0,76 | 1,1 | 1,8 | 3,4 | 4,5 | 7,4 | 13,6 | 19,2 | 33,3 | 38 | 79 | |

| Bores | | | | Size | | | | | | | | | | |
|--------------------------------|------------------------------------|-----------|----|------|----|----|----|----|----|-----|--------------------|--------------------|-----|------|
| | | | | 2 | 4 | 8 | 16 | 32 | 60 | 100 | 150 | 250 | 500 | 1000 |
| Bore $\varnothing d_{H7}^{2)}$ | Standard brake Type 891.0_2_... | min. [mm] | 8 | 10 | 11 | 14 | 19 | 22 | 24 | 30 | 40 ^{1.1)} | 50 ^{1.1)} | 75 | |
| | | max. [mm] | 15 | 15 | 20 | 25 | 30 | 35 | 45 | 50 | 60 | 80 | 90 | |
| | Please observe Table 2, page 7 | | | | | | | | | | | | | |
| | Holding brake Type 891.1_... | min. [mm] | 8 | 10 | 11 | 14 | 19 | 22 | 24 | 30 | 40 | 50 | 75 | |
| max. [mm] | | 15 | 15 | 20 | 25 | 30 | 35 | 45 | 50 | 55 | 75 | 90 | | |
| Please observe Table 2, page 7 | | | | | | | | | | | | | | |

| Dimensions [mm] | Size | | | | | | | | | | |
|-----------------|-------|------|-------|------|------|-------|-----|-----|------|-----|------|
| | 2 | 4 | 8 | 16 | 32 | 60 | 100 | 150 | 250 | 500 | 1000 |
| a | 0,15 | 0,15 | 0,2 | 0,2 | 0,2 | 0,25 | 0,3 | 0,3 | 0,35 | 0,4 | 0,5 |
| b | 30 | 30 | 36 | 42 | 52 | 60 | 78 | 84 | 96 | 130 | 180 |
| b ₁ | 30 | 30 | 36 | 42 | 52 | 62 | - | - | - | - | - |
| c | 24 | 26,5 | 28,7 | 35,5 | 39,2 | 50,5 | 54 | 59 | 69 | 70 | 85 |
| c ₁ | 25 | 27,5 | 29,7 | 36,8 | 40,5 | 51,8 | - | - | - | - | - |
| c ₂ | 29 | 32,5 | 34,7 | 42,5 | 47,2 | 58,5 | 64 | 71 | 83 | 89 | 106 |
| D | 76 | 87 | 103 | 128 | 148 | 168 | 200 | 221 | 258 | 310 | 382 |
| D ₁ | 81 | 92 | 108 | 130 | 148 | 168 | 200 | 221 | 258 | 310 | 382 |
| D ₂ | 81 | 92 | 108 | 134 | 154 | 174 | 206 | 227 | 266 | 318 | 392 |
| F | 48,5 | 54 | 63,5 | 77 | 88 | 100,5 | 123 | 133 | 153 | 179 | - |
| F ₁ | 102,5 | 108 | 117,5 | 131 | 169 | 228,5 | 267 | 347 | 494 | 521 | - |
| f | 8 | 8 | 8 | 8 | 10 | 14 | 14 | 19 | 23 | 23 | - |

ROBA-stop®-M – electromagnetic safety brakes

Type 891..._2.0
Standard with friction disk

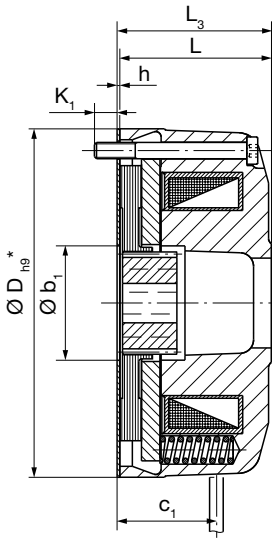

Type 891..._4.1
Enclosed design (IP 65)
with flange plate

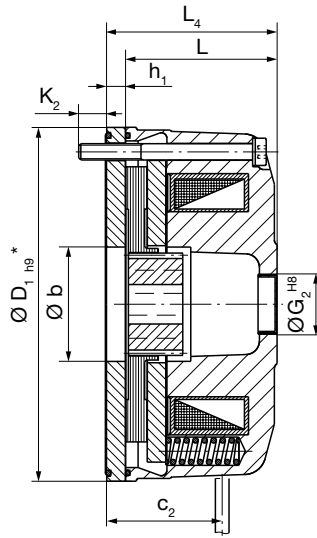

Type 891..._4.2
Tacho attachment design
with flange plate

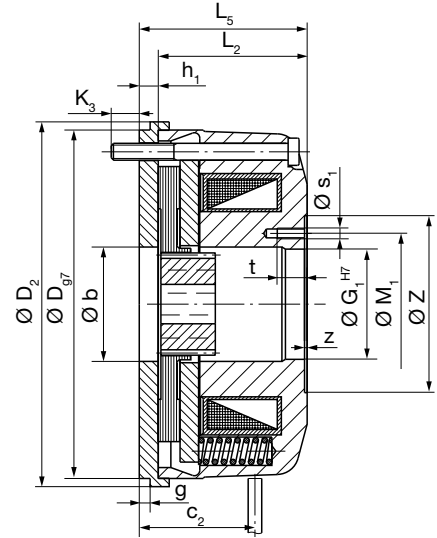

* Outer diameter friction disk: free Size; outer diameter flange plate: -0.2

Missing dimensions are identical with Type 891.011.0 see page 4.

| Dimensions [mm] | Size | | | | | | | | | | | |
|-----------------------------------|------------------------------|--------|--------|--------|--------|--------|--------|--------|---------|------------------|-----------------------|--|
| | 2 | 4 | 8 | 16 | 32 | 60 | 100 | 150 | 250 | 500 | 1000 | |
| G | 16,5 | 18 | 22 | 33 | 36 | 38 | 48 | 55 | 65 | 85 | 100 | |
| G₁ | 23,5 | 28,5 | 32,5 | 40,5 | 52,5 | 60 | 75,5 | 82,5 | 92 | 131 | 100 | |
| G₂^{H8} | - | - | 22 | 22 | 28 | 32 | 42 | 48 | 52 | 62 | 100 | |
| g | 4 | 4 | 4 | 4 | 4 | 4 | 5 | 6 | 7 | 7 | 7 | |
| H | 16 | 14,5 | 17,5 | 26 | 27 | 26 | 34 | 41 | 46 | 54,5 | - | |
| h | 1 | 1 | 1 | 1,25 | 1,25 | 1,25 | - | - | - | - | - | |
| h₁ | 5 | 6 | 6 | 7 | 8 | 8 | 10 | 12 | 14 | 19 | 21 | |
| K | 10 | 10,8 | 12,5 | 12,3 | 8,3 | 12 | 12 | 20 | 20 | 22 | 18,5 | |
| K₁ | 9 | 9,8 | 11,5 | 11,1 | 7,1 | 10,8 | - | - | - | - | - | |
| K₂ | 10 | 8,8 | 11,5 | 10,3 | 10,3 | 14 | 12 | 18 | 25,5 | 21,5 | 17,5 | |
| K₃ | 10 | 9,8 | 11,5 | 10,3 | 10,3 | 14 | 12 | 18 | 26 | 23 | 19 | |
| L | 39 | 41,5 | 45,2 | 55,7 | 61,7 | 72,5 | 84 | 97 | 116 | 114 | 135 ^{6) 7)} | |
| L₂ | 38 | 40,5 | 44,2 | 54,7 | 60,7 | 71,5 | 83 | 96 | 115 | 113 | 135 ⁷⁾ | |
| L₃ | 40 | 42,5 | 46,2 | 57 | 63 | 73,8 | - | - | - | - | - | |
| L₄ | 44 | 47,5 | 51,2 | 62,7 | 69,7 | 80,5 | 94 | 109 | 130 | 133 | 170 ⁶⁾ | |
| L₅ | 43 | 46,5 | 50,2 | 61,7 | 68,7 | 79,5 | 93 | 108 | 129 | 132 | 156 ⁷⁾ | |
| l | 18 | 18 | 20 | 20 | 25 | 30 | 30 | 35 | 40 | 50 ⁴⁾ | 70 | |
| | supporting length of the key | | | | | | | | | | | |
| M | 66 | 72 | 90 | 112 | 132 | 145 | 170 | 196 | 230 | 278 | 325 | |
| M₁ | 29 | 35 | 41 | 52 | 61 | 75 | 88 | 100 | 112 | 145 | 115,5 | |
| R | 57 | 65 | 81 | 101 | 121 | 130,5 | 154 | 178 | 206 | 253 | 300 | |
| r | 45 | 45 | 53 | 70 | 83 | 94 | 106 | 122 | 140 | 161 | 190 | |
| s | 3 x M4 | 3 x M4 | 3 x M5 | 3 x M6 | 3 x M6 | 3 x M8 | 3 x M8 | 3 x M8 | 3 x M10 | 6 x M10 | 6 x M12 ⁹⁾ | |
| s₁ | 3 x M3 | 3 x M4 | 3 x M4 | 3 x M4 | 3 x M5 | 3 x M5 | 3 x M5 | 3 x M6 | 3 x M6 | 6 x M8 | 6 x M6 | |
| t | 6 | 10 | 10 | 10 | 10 | 10 | 10 | 10 | 10 | 13 | 12 | |
| x | 0 | 0 | 0 | 0-0,5 | 0-0,5 | 0-2 | 0-3 | 0-3 | 0-3 | 3-4 | 0-1,5 | |
| Z | 36 | 45 | 55 | 65 | 75 | 90 | 100 | 115 | 130 | 175 | - | |
| z | 1 | 1 | 1 | 1 | 1 | 1 | 1 | 1 | 1 | 1 | - | |

Standard voltages 24; 104; 180; 207 V.
Permitted voltage tolerance acc. DIN IEC 60038 (±10 %).

We reserve the right to make dimensional and constructional alterations.

- 1) Braking torque tolerance on Sizes 2–250 = +30 %/-10 %, for other adjustments see Table 3, page 7 and Type key page 3.
 - 1.1) Minimum bore not permitted for braking torque adjustment = 125 %.
 - 1.2) Braking torque tolerance = +40 %/-20 % (slight grinding necessary).
- 2) The respective maximum bores are to be seen in relation to the corresponding keyways and their tolerances acc. Table 2 page 7.
- 3) Brake operation from 700 Nm on only possible with overexcitation.
- 4) Hub facing side (both sides) 3 mm deep, Ø 97 recessed.
- 5) Brake operation only possible with overexcitation.
- 6) The IP65 design is equipped with a sealing cover on Size 1000: L = 149 mm, L₄ = 170 mm.
- 7) Projection screw plugs (emergency hand release): 8,5 mm
- 8) For flange plate securement: additional 2 x M12 screws (dimensions available on request).

ROBA-stop®-M – Short Description Installation

Installation Conditions

- ❑ The eccentricity of the shaft end against the mounting pitch circle must not exceed 0,2 mm.
- ❑ The position tolerance of the threaded holes for the cap screws (8, Fig. 2) must not exceed 0,2 mm.
- ❑ The axial run-out deviation of the screw-on surface to the shaft must not exceed the permitted axial run-out tolerance according to DIN 42955. Larger deviations can lead to a drop in torque, to continuous slipping on the rotors and to overheating.

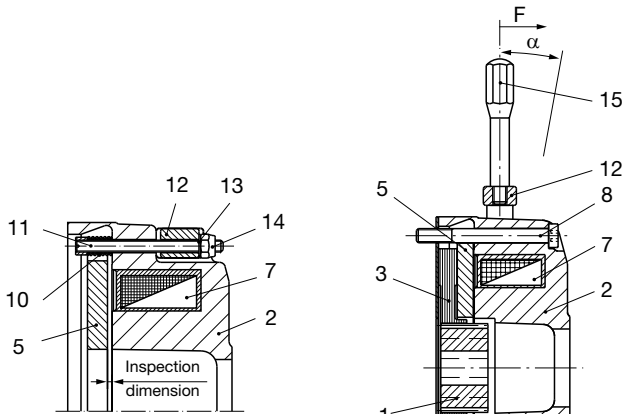

Fig. 1

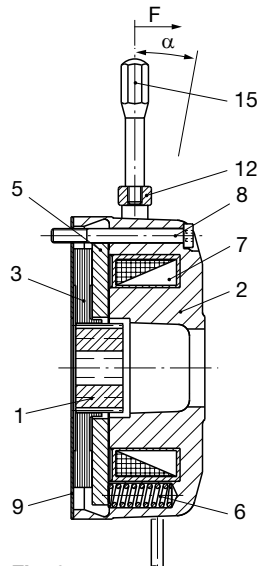

Fig. 2

Installation

ROBA-stop®-M brakes are very easy to install:

1. Mount the hub (1) onto the shaft and secure it axially (e.g. using a locking ring).
 - Recommended tolerance of hub-shaft connection = H7/k6.
 - Avoid too tight hub-shaft connections (especially on max. bores). They lead to the rotor (3) jamming on the hub (1) and therefore to brake malfunctions.
 - Keep the friction surfaces free of oil and grease.

Caution!

Please observe supporting length of the key acc. Dimensions on page 5.

2. If necessary (dependent on Type), move the friction disk or the flange plate over the shaft and attach it to the machine wall (or screw on for Size 1000).
 - If there are no suitable counter-friction surfaces made of grey cast or steel available, please use brake Types 891._ _2/3._ _ (with friction disk (9)) or 891._ _4/5._ _ (with flange plate).
 - When using a brake with a friction disk (Type 891._ _2/3._ _), please observe the stamp "friction side" on the friction disk.
3. Push the rotor (3) onto the hub (1) by hand.
4. If necessary, install the hand release (only on Sizes 2 - 500/the emergency hand release is partly assembled on Size 1000).
5. If necessary (dependent on Type, Type 891._ _ _1), insert the O-ring into the axial recess of the coil carrier (2).
6. Push the rest of the brake over the hub (1) and the rotor collar (3).
7. Attach the brake to the motor bearing shield or onto the machine wall evenly all around by using the cap screws (8) incl. the manufacturer-side mounted flat sealing ring (dependent on Type, Type 891._ _ _1), torque wrench and tightening torque (acc. Table 1, page 7).

Caution!

Only use mayr® original screws (Table 1, page 7).

Braking Torque Adjustment

It is possible to achieve different torque settings or torque reductions by using different spring configurations (6) in the coil carrier (2) (see Table 3, page 7).

Design with continuous setting available on request.

Hand Release Installation (Sizes 2 – 500)

On Type 891._ _ _1 installation of the hand release is only possible if a request for a hand release is stated on the brake order form (completely enclosed coil carrier (2)).

The brake must be dismantled and de-energised for the hand release installation.

Installation Procedure (Figs. 1 and 2):

1. Unscrew brake from the motor bearing shield or from the machine wall.
2. Remove the sealing plugs from the hand release bores in the coil carrier (2).
3. Put the thrust springs (10) onto the threaded bolts (11). The threaded bolts (11) are manufacturer-side produced with a key as a tension element and are secured with glue up to Size M60. This connection must not be loosened.
4. Push the threaded bolts (11) with thrust springs (10) from the inside (facing the magnetic coil (7)) into the hand release bores in the coil carrier (2).
5. Push the O-rings (only with sealed hand release, Type 891._ _ _1) over the threaded bolts (11) and insert them into the recesses of the coil carrier (2).
6. Push intermediate plates (only with sealed hand release, Type 891._ _ _1) over the threaded bolts (11).
7. Put the switch bracket (12) in place, put washers (13) onto it and lightly screw on the self-locking hexagon nuts (14).
8. Tighten both hexagon nuts (14) until the armature disk (5) lies evenly on the coil carrier (2).
9. Loosen both hexagon nuts (14) by "Y" turns (see Table 1, page 7), thereby creating an air gap between the armature disk (5) and the coil carrier (2) or the inspection dimension "x" (Fig. 1).

Caution!

An unequal alignment dimension on the hand release can cause the brake to malfunction.

10. After installing the release cover, screw the hand release bar (15) into the switch bracket (12) and tighten it. The hand release bar (15) must be protected against loosening with a screw-securing product, e.g. Loctite 243.

Maintenance

ROBA-stop®-M brakes are mainly maintenance-free.

However, the rotor (3) is subject to functional wear. The friction linings are robust and wear-resistant. This ensures a particularly long service lifetime.

However, if the rotor (3) does become worn due to high total friction work, the brake can be brought back into its original functional condition by replacing the rotor. For this, the brake must be cleaned thoroughly.

The wear condition of the rotor (3) is determined by measuring the release voltage (this must not exceed max. 90 % of the nominal voltage on a warm brake), or by measuring the rotor thickness on a dismantled brake ("minimum rotor thickness" acc. Table in the currently valid Installation and Operational Instructions). On Sizes 500 and 1000 there is an air gap inspection opening. This means that the brake does not have to be dismantled.

Caution!

The brake function cannot be guaranteed on brakes with a reduced braking torque and/or operation with a fast-acting rectifier if the friction linings are heavily worn.

Unpermittedly high wear cannot be recognized via the switching behaviour of the brake, as in this constellation the magnetic coil (7) is able to manage a very high tension path of the armature disk (5). Unpermittedly high wear causes the thrust springs (6) to relax, which results in a decrease in torque.

ROBA-stop®-M – Short Description Installation

| Technical Data for Installation | | | Size | | | | | | | | | | | |
|--|---|------|---------------------|---------------------|---------------------|---------------------|---------------------|---------------------|---------------------|---------------------|---------------------|---------------------|---------------|---------------|
| | | | 2 | 4 | 8 | 16 | 32 | 60 | 100 | 150 | 250 | 500 | 1000 | |
| Inspection dimension | x | [mm] | 0,9 ^{+0,1} | 0,9 ^{+0,1} | 1,1 ^{+0,1} | 1,6 ^{+0,1} | 1,8 ^{+0,1} | 2,2 ^{+0,1} | 2,2 ^{+0,1} | 2,2 ^{+0,1} | 2,4 ^{+0,1} | 2,4 ^{+0,1} | - | |
| Number of rotations | Y | [-] | 1,7 | 1,7 | 1,5 | 2,0 | 2,0 | 2,0 | 1,6 | 1,6 | 1,5 | 1,5 | - | |
| Release force | Standard brake Type 891.0 ₂ _ _ _ | F | [N] | 20 | 35 | 70 | 100 | 130 | 220 | 260 | 290 | 350 | 310 | - |
| | Holding brake Type 891.10 _ _ _ | F | [N] | 26 | 45 | 90 | 125 | 170 | 300 | 340 | 350 | 430 | 470 | - |
| Release angle | α | [°] | 6 | 7 | 7 | 7 | 8 | 10 | 12 | 13 | 10 | 10 | - | |
| Fixing screws (Item 8) | Type 891. _ _ 0. _ | - | [mm] | 3 x M4 x 45 | 3 x M4 x 45 | 3 x M5 x 50 | 3 x M6 x 60 | 3 x M6 x 60 | 3 x M8 x 75 | 3 x M8 x 80 | 3 x M8 x 100 | 3 x M10 x 110 | 6 x M10 x 110 | 6 x M12 x 130 |
| | | | | DIN | 6912 | 6912 | 6912 | 6912 | 6912 | 6912 | EN ISO 4762 | EN ISO 4762 | EN ISO 4762 | EN ISO 4762 |
| | Type 891. _ _ 4. _ | - | [mm] | 3 x M4 x 50 | 3 x M4 x 50 | 3 x M5 x 55 | 3 x M6 x 65 | 3 x M6 x 70 | 3 x M8 x 85 | 3 x M8 x 90 | 3 x M8 x 110 | 3 x M10 x 130 | 6 x M10 x 130 | 6 x M12 x 150 |
| | | | | DIN | EN ISO 4762 | EN ISO 4762 | 6912 | 6912 | EN ISO 4762 | EN ISO 4762 | EN ISO 4762 | EN ISO 4762 | EN ISO 4762 | EN ISO 4762 |
| Tightening torque for screws (Item 8, Fig. 2, page 6) | T _A | [Nm] | 2,5 | 2,5 | 5,0 | 9,0 | 9,0 | 22 | 22 | 22 | 45 | 45 | 83 | |
| Rotor thickness "new condition" | | [mm] | 6,05 | 6,05 | 6,9 | 8 | 10,4 | 11,15 | 14 | 15,5 | 17 | 18,5 | 18,5 | |

Table 1

| Permitted Bores Ø d _{max} | | | Size | | | | | | | | | | |
|------------------------------------|-------------------------------|---------------|------|----|----|----|----|----|-----|-----|-----|-----|------|
| | | | 2 | 4 | 8 | 16 | 32 | 60 | 100 | 150 | 250 | 500 | 1000 |
| Ø d _{max} | Type 891.0 ₂ _ _ _ | Keyway 6885/1 | 13 | 13 | 18 | 22 | 30 | 32 | 42 | 45 | 55 | 75 | 90 |
| | | JS9 6885/3 | 15 | 15 | 20 | 25 | - | 35 | 45 | 50 | 60 | 80 | - |
| | | Keyway 6885/1 | 13 | 13 | 18 | 20 | 28 | 32 | 42 | 45 | 50 | 75 | 90 |
| | | P9 6885/3 | 15 | 15 | 20 | 22 | 30 | - | 45 | 50 | 55 | 80 | - |
| | Type 891.1 _ _ _ | Keyway 6885/1 | 13 | 13 | 18 | 22 | 30 | 32 | 42 | 45 | 55 | 75 | 90 |
| | | JS9 6885/3 | 15 | 15 | 20 | 25 | - | 35 | 45 | 50 | - | - | - |
| | Keyway 6885/1 | 13 | 13 | 18 | 20 | 28 | 32 | 42 | 45 | 50 | 75 | 90 | |
| | P9 6885/3 | 15 | 15 | 20 | 22 | 30 | - | 45 | 50 | 55 | - | - | |

Table 2

| Braking Torque Adjustments | | | Size | | | | | | | | | | | |
|----------------------------|--------------------------------------|-------|------|-----|-----|-----|------|-----|-----|-----|-----|-------------------|--------------------|------|
| | | | 2 | 4 | 8 | 16 | 32 | 60 | 100 | 150 | 250 | 500 | 1000 ³⁾ | |
| Holding brake | | [Nm] | 4 | 8 | 16 | 32 | 64 | 100 | 180 | 250 | 450 | 800 ²⁾ | 1600 | |
| Standard brake | Braking torque ⁴⁾ in % | 125 % | [Nm] | 2,5 | 5 | 10 | 20 | 40 | 75 | 125 | 185 | 312 | 700 ¹⁾ | 1400 |
| | | 112 % | [Nm] | 2,2 | 4,5 | 9 | 18 | 36 | 68 | 110 | 165 | 280 | 600 | 1200 |
| | | 100 % | [Nm] | 2 | 4 | 8 | 16 | 32 | 60 | 100 | 150 | 250 | 500 | 1000 |
| | | 84 % | [Nm] | 1,7 | 3,4 | 6,8 | 13,5 | 27 | 51 | 85 | 125 | 215 | 400 | 800 |
| | | 68 % | [Nm] | 1,4 | 2,8 | 5,5 | 11 | 22 | 42 | 70 | 100 | 180 | 350 | 700 |
| | | 50 % | [Nm] | 1 | 2 | 4 | 8 | 16 | 30 | 50 | 75 | 125 | 250 | 500 |
| | | 34 % | [Nm] | 0,7 | 1,4 | 2,8 | 5,5 | 11 | 21 | 35 | 50 | 90 | 200 | 400 |

Table 3

1) Brake operation only as holding brake.
 2) Brake operation from 700 Nm only possible with overexcitation.
 3) Brake operation only possible with overexcitation.

4) The braking torque (switching torque) is the torque effective in the shaft train of a slipping brake with a sliding speed of 1 m/s in relation to the mean friction radius (acc. VDE 0580/07.2000).

ROBA-stop®-M – Brake Dimensioning

Brake Size Selection

1. Brake selection

$$M_{\text{erf.}} = \frac{9550 \times P}{n} \times K \leq M_2 \quad [\text{Nm}]$$

$$t_v = \frac{J \times n}{9,55 \times M_v} \quad [\text{sec}]$$

$$t_4 = t_v + t_1 \quad [\text{sec}]$$

$$M_v = M_2 + (-) \times M_L \quad [\text{Nm}]$$

2. Inspection of thermic load

$$Q_r = \frac{J \times n^2}{182,4} \times \frac{M_2}{M_v} \quad [\text{J}]$$

The permitted friction work (switching work) $Q_{r \text{ zul.}}$ per braking for the specified switching frequency can be taken from the Friction-Power Diagrams (page 9).

If the friction work (switching work) per braking is known, the max. switching frequency can also be taken from the Friction-Power Diagrams (page 9).

Key:

| | | |
|----------------------|---------------------|--|
| J | [kgm ²] | Mass moment of inertia |
| K | [-] | Safety factor (1 – 3 x acc. to conditions) |
| $M_{\text{erf.}}$ | [Nm] | Required braking torque |
| M_v | [Nm] | Delaying torque |
| M_L | [Nm] | Load torque * sign in brackets is valid if load is braked during downward movement |
| M_2 | [Nm] | Nominal torque (Technical Data page 4) |
| n | [rpm] | Speed |
| P | [kW] | Input power |
| t_v | [s] | Braking action |
| t_1 | [s] | Connection time (Table 6 page 11) |
| t_4 | [s] | Total switch-on time |
| Q_r | [J] | Friction work present per braking |
| $Q_{r 0,1}$ | [J] | Friction work per 0,1 mm wear (Table 4) |
| $Q_{r \text{ ges.}}$ | [J] | Friction work up to rotor replacement (Table 4) |
| $Q_{r \text{ zul.}}$ | [J] | Permitted friction work (switching work) per braking |



Due to operating parameters such as slipping speed, pressing or temperature, the **wear values** can only be considered **guideline values**.

When using a brake with a friction disk (Type 891._.2.), the max. friction work and friction power must be reduced by 30 % for Sizes 2 to 16 and by 50 % for Sizes 32 – 60. The wear values $Q_{r 0,1}$ and $Q_{r \text{ ges.}}$ are therefore not valid.

| Friction Work | | | | Size | | | | | | | | | | |
|-------------------------|-----------------------------------|----------------------|---------------------|------|-----|-----|-----|-----|-----|-----|-----|------|------|------|
| | | | | 2 | 4 | 8 | 16 | 32 | 60 | 100 | 150 | 250 | 500 | 1000 |
| Per 0,1 mm wear | Standard brake Type 891.0_2_-- | $Q_{r 0,1}$ | [10 ⁶ J] | 35 | 40 | 65 | 100 | 130 | 130 | 140 | 150 | 160 | 170 | 180 |
| | Holding brake Type 891.1_-- | $Q_{r 0,1}$ | [10 ⁶ J] | 7 | 8 | 13 | 20 | 30 | 65 | 70 | 75 | 80 | 85 | 90 |
| Up to rotor replacement | Standard brake Type 891.0_2_-- | $Q_{r \text{ ges.}}$ | [10 ⁶ J] | 95 | 100 | 162 | 500 | 600 | 700 | 840 | 950 | 1000 | 1700 | 2000 |
| | Holding brake Type 891.1_-- | $Q_{r \text{ ges.}}$ | [10 ⁶ J] | 7 | 8 | 13 | 20 | 45 | 130 | 170 | 300 | 350 | 425 | 540 |

Table 4

| Mass Moment of Inertia | | | | Size | | | | | | | | | | |
|--|--|-----------|--------------------------------------|------|------|------|------|------|------|-------|-------|-------|-------|------|
| | | | | 2 | 4 | 8 | 16 | 32 | 60 | 100 | 150 | 250 | 500 | 1000 |
| Rotor + hub at d_{max} | | J_{R+H} | [10 ⁻⁴ kgm ²] | | | | | | | | | | | |
| Type 891.0_1_-- (Metal rotor) | | J_{R+H} | [10 ⁻⁴ kgm ²] | 0,12 | 0,21 | 0,67 | 1,74 | 4,48 | 6,74 | 16,54 | 31,68 | 61,82 | 222,6 | 424 |
| Type 891.2_-- (Friction lining rotor) | | J_{R+H} | [10 ⁻⁴ kgm ²] | 0,1 | 0,17 | 0,58 | 1,53 | 4,1 | - | - | - | - | - | - |

Table 5

ROBA-stop[®]-M – Friction-Power Diagrams

**Type 891.01_._
and
Type 891.21_._
(Standard brake)**
for 50 %
of the maximum speed n_{max}

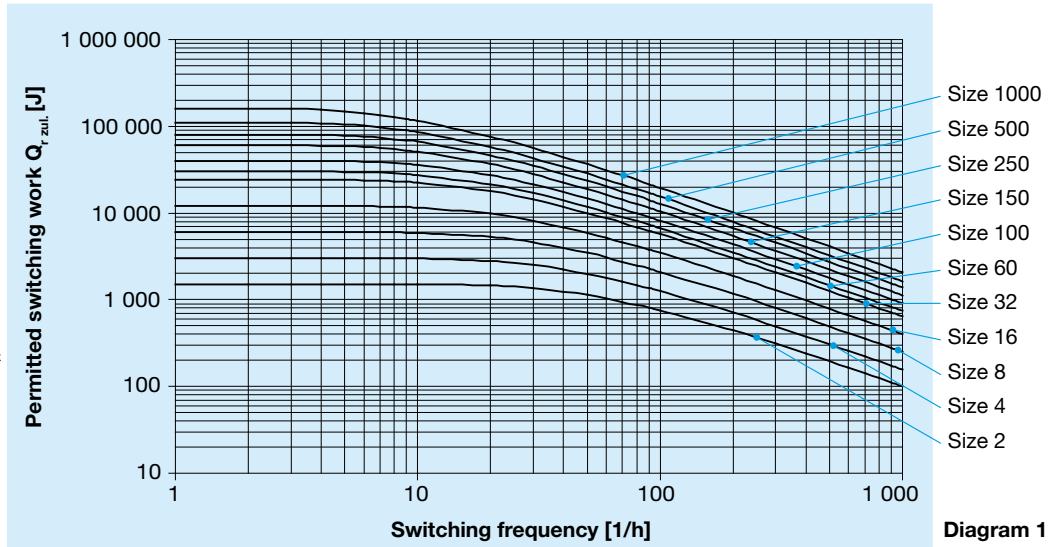

**Type 891.01_._
and
Type 891.21_._
(Standard brake)**
for the
maximum speed n_{max}

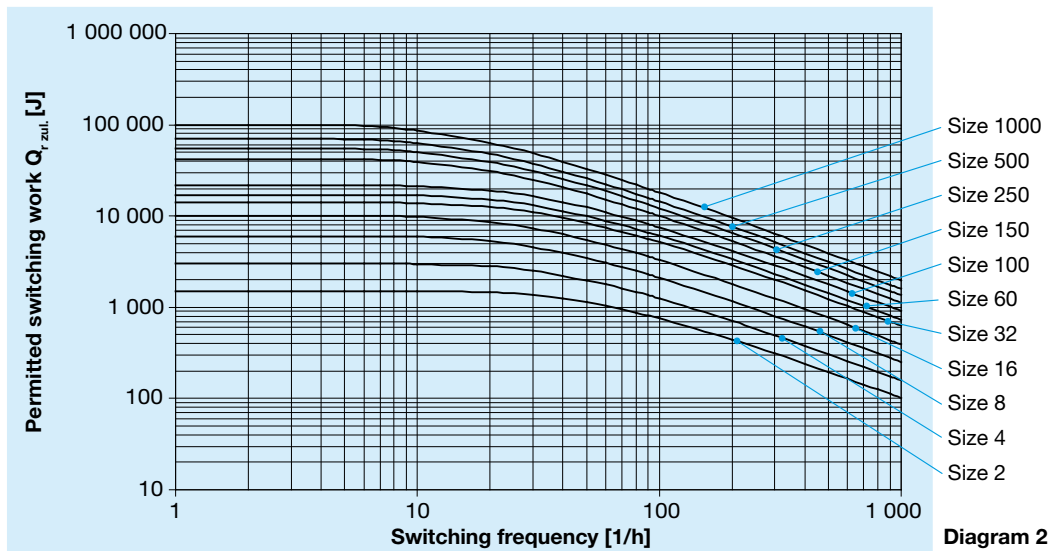

Type 891.10_._ (Holding brake)
for 50 % of the maximum speed n_{max}

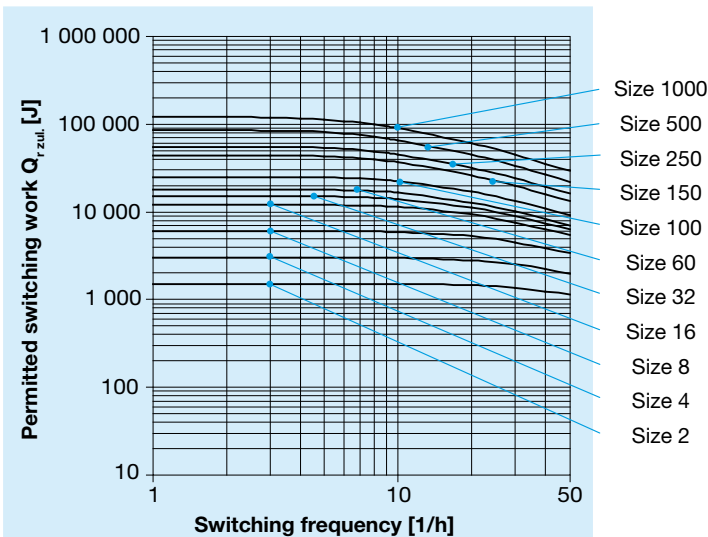

Type 891.10_._ (Holding brake)
for the maximum speed n_{max}

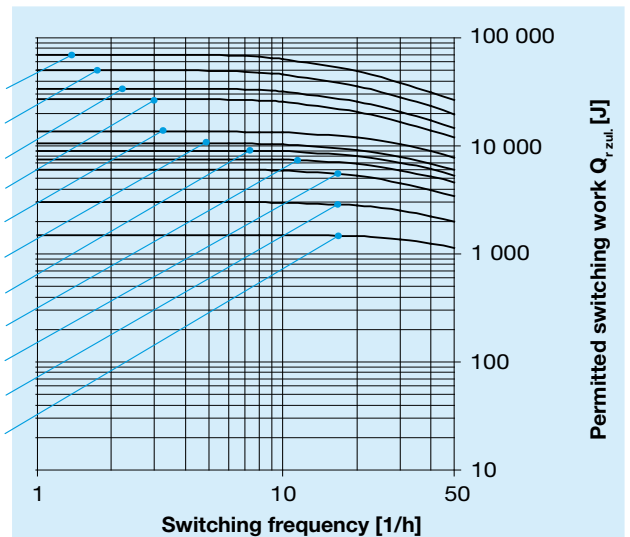

ROBA-stop[®]-M – Further Options

In addition to the standard brakes, *mayr*[®] power transmission provides a multitude of further designs, which cannot be described in detail in this catalogue.

Some of the most frequently requested options are:

- Microswitch for switching condition indication (release monitoring)
- Microswitch for wear indication (wear monitoring)
- Special coil voltages
- Lockable hand release
- IP65 design for continuous shafts
- Noise damping (O-ring damping between the gear hub and the rotor)
- Anti-condensation heating
- Customer-specific flange plate
- Double rotor design
- Special lubricating material
- ATEX design

Please contact *mayr*[®] for further information.

Release monitoring

When the magnetic coil in the coil carrier (2) is energised, the armature disk (3) is pulled towards the coil carrier (2). The microswitch (1) emits a signal and the brake is released.

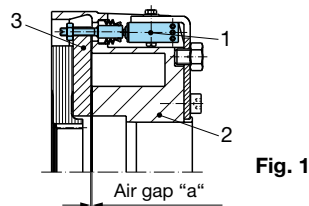

Fig. 1

Wear monitoring

Due to wear on the rotor (5), the nominal air gap "a" between the coil carrier (2) and the armature disk (3) increases. If the limit air gap (see Table in the Installation and Operational Instructions) is reached, the microswitch contact (1) switches over and emits a signal. The rotor (5) must be replaced.

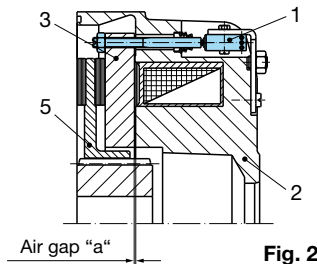

Fig. 2

Lockable hand release

In de-energised condition, the brake with lockable hand release can be released manually. By moving the hand release rod (1), the armature disk (3) is pushed against the thrust springs (4) onto the coil carrier (2) and the braking torque is removed, Figs. 3a and 3b.

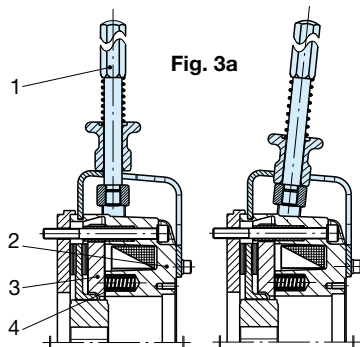

Fig. 3a

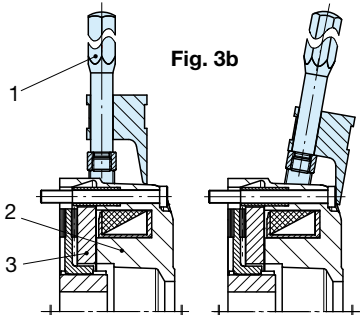

Fig. 3b

| | | Hand release in starting position | Hand release in engaged position |
|------|--------------|-----------------------------------|----------------------------------|
| Coil | de-energised | Shaft braked | Shaft runs free |
| | energised | Shaft runs free | Shaft runs free |

Continuous shaft with IP65

The enclosed design (IP65) is equipped with a screw plug (Sizes 8 to 500) or with a sealing cover (Size 1000) (see Type 891...14.1, page 5) as part of the standard delivery.

A radial shaft sealing ring (1) is installed in the coil carrier (2) on continuous shafts.

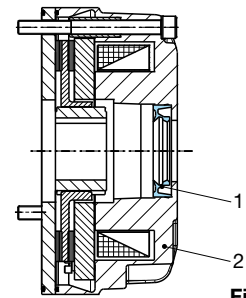

Fig. 4

Damping rotor/gear hub

If vibrations in the drive line cannot be avoided, an O-ring (1) is used to damp backlash between the gear hub (6) and the rotor (5).

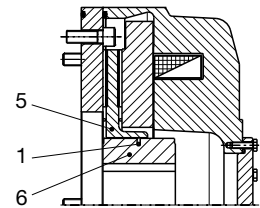

Fig. 5

Anti-condensation heating

The anti-condensation heating (1) is used to prevent condensation formation inside the brake.

This product is particularly useful at temperatures of under zero degrees Celsius or in high humidity.

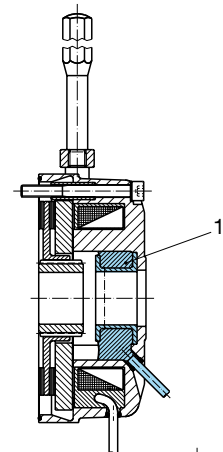

Fig. 6

Special flange plate

We offer a range of flange plates for customer-specific solutions, such as for example the special flange plate shown in Fig. 7 (1) with customer-tailored centring (8) and sealing (7).

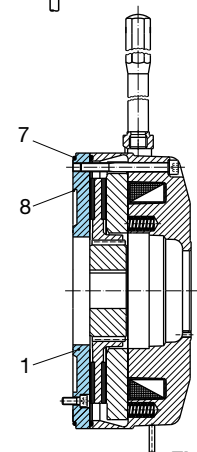

Fig. 7

Double rotor design

Double rotor design for increased torque at small outside diameter, Fig. 8.

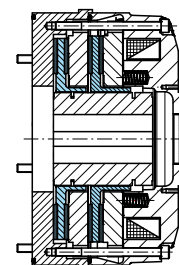

Fig. 8

ROBA-stop®-M – Switching Times / Electrical Connection

Switching Times

The values are mean values which refer to the nominal air gap and the nominal torque (100 %) for a warm brake.
For other braking torque adjustments, see Diagram: “Brake separation time t_2 dependent on spring configuration” on page 12.

| Switching Times | | | Size | | | | | | | | | | |
|------------------------------|-------------------|-----------------|------|-----|-----|-----|-----|-----|-----|-----|------|------|-------|
| | | | 2 | 4 | 8 | 16 | 32 | 60 | 100 | 150 | 250 | 500 | 1000 |
| Nominal torque (100 %) | | M_{nenn} [Nm] | 2 | 4 | 8 | 16 | 32 | 60 | 100 | 150 | 250 | 500 | 1000 |
| Connection time | DC-side switching | t_1 [ms] | 10 | 18 | 20 | 30 | 50 | 55 | 68 | 80 | 100 | 100 | 180 |
| | AC-side switching | t_1 [ms] | 100 | 160 | 220 | 320 | 400 | 500 | 640 | 730 | 1100 | 1100 | 1200 |
| Response delay on connection | DC-side switching | t_{11} [ms] | 6 | 12 | 16 | 25 | 35 | 35 | 38 | 40 | 50 | 30 | 70 |
| | AC-side switching | t_{11} [ms] | 80 | 130 | 175 | 240 | 300 | 350 | 400 | 450 | 700 | 700 | 750 |
| Separation time | | t_2 [ms] | 28 | 30 | 45 | 70 | 100 | 150 | 180 | 220 | 290 | 400 | 270 * |

Table 6

* Value in operation with overexcitation

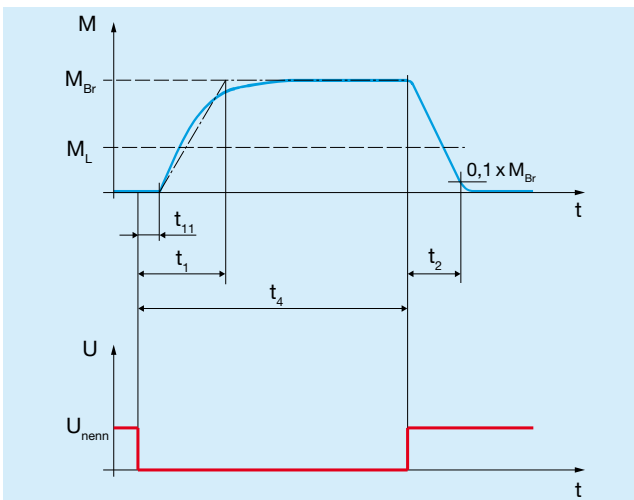

Diagram 5: Torque-Time

Key:

- M_{Br} = Braking torque
- M_L = Load torque
- t_1 = Connection time
- t_{11} = Response delay on connection
- t_2 = Separation time
- t_4 = Slip time + t_{11}
- U_{nenn} = Coil nominal voltage

Electrical Connection and Wiring

DC current is necessary for the operation of the brake. The coil voltage is indicated on the Type tag as well as on the brake body and is designed according to the DIN IEC 60038 ($\pm 10\%$ tolerance). Operation is possible both via alternating voltage in connection with a rectifier or with another suitable DC supply. Dependent on the brake equipment, the connection possibilities can vary. Please follow the exact connections according to the Wiring Diagram. The manufacturer and the user must observe the applicable directives and standards (e.g. DIN EN 60204-1 and DIN VDE 0580). Their observance must be guaranteed and double-checked.

Earthing Connection

The brake is designed for Protection Class I. This protection covers not only the basic insulation but also the connection of all conductive parts to the PE conductor on the fixed installation. If the basic insulation fails, no contact voltage will remain. Please carry out a standardized inspection of the PE conductor connections to all contactable metal parts.

Device Fuses

To protect against damage from short circuits, please add suitable device fuses to the mains cable.

Switching Behaviour

The operational behaviour of a brake is to a large extent dependent on the switching mode used. Furthermore, the switching times are influenced by the temperature and the air gap between the armature disk and the coil carrier (dependent on the wear condition of the linings).

Magnetic Field Build-up

When the voltage is switched on, a magnetic field is built up in the brake coil, which attracts the armature disk to the coil carrier and releases the brake.

• Field Build-up with Normal Excitation

If we energise the magnetic coil with nominal voltage, the coil voltage does not immediately reach its nominal value. The coil inductivity causes the current to rise slowly as an exponential function. Accordingly, the build-up of the magnetic field happens more slowly and the braking torque drop (curve 1, below) is also delayed.

• Field Build-up with Overexcitation

A quicker and safer drop in braking torque is achieved if the coil is temporarily placed under a higher voltage than the nominal voltage, as the current then increases more quickly. Once the brake is released, it is possible to switch to the nominal voltage (curve 2, below). The relationship between the overexcitation and the separation time t_2 is roughly proportional indirectly; this means that at doubled nominal voltage (overexcitation voltage), the separation time t_2 for brake release is halved. The ROBA®-switch fast-acting rectifier works on this principle.

Current path

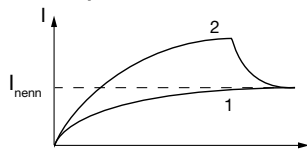

Braking torque path

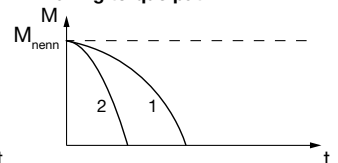

Operation with overexcitation requires testing of:

- the necessary overexcitation time * (page 12)
- as well as of the RMS coil capacity ** for a cycle frequency higher than 1 cycle per minute (page 12).

ROBA-stop®-M – Electrical Connection

* Overexcitation time $t_{\text{über}}$

Increased wear and therefore an enlarged air gap as well as coil heat lengthen the separation time t_2 of the brake. Therefore, as overexcitation time $t_{\text{über}}$, please select at least double the separation time t_2 with nominal power on each brake Size.

The spring forces also influence the brake separation time t_2 : Higher spring forces increase the separation time t_2 and lower spring forces reduce the separation time t_2 . The separation time t_2 alterations due to the spring configuration can be seen in the adjoining diagram.

- Spring force (braking torque adjustment) < 100 %:

The overexcitation time $t_{\text{über}}$ is less than double the separation time t_2 on each brake Size.

Example: braking torque adjustment = 34 %

--> separation time $t_2 = 50 %$

--> overexcitation time $t_{\text{über}} = 200 % \times 50 % = 100 % t_2$

- Spring force (braking torque adjustment) = 100 %:

The overexcitation time $t_{\text{über}}$ is double the separation time t_2 on each brake Size.

- Spring force (braking torque adjustment) > 100 %:

The overexcitation time $t_{\text{über}}$ is higher than double the separation time t_2 on each brake Size.

Example: braking torque adjustment = 125 %

--> separation time $t_2 = 120 %$

--> overexcitation time $t_{\text{über}} = 200 % \times 120 % = 240 % t_2$

** Coil capacity P_{RMS}



$$P_{\text{RMS}} \leq P_{\text{nenn}}$$

The coil capacity P_{RMS} must not be larger than P_{nenn} . Otherwise, the coil may fail due to thermic overload.

Calculations:

P_{RMS} [W] RMS coil capacity, dependent on switching frequency, overexcitation, power reduction and switch-on time duration

$$P_{\text{RMS}} = \frac{P_{\text{über}} \times t_{\text{über}} + P_{\text{halte}} \times t_{\text{halte}}}{t_{\text{ges}}}$$

P_{nenn} [W] Coil nominal capacity (Catalogue values or Type tag)

$P_{\text{über}}$ [W] Coil capacity on overexcitation

$$P_{\text{über}} = \left(\frac{U_{\text{über}}}{U_{\text{nenn}}} \right)^2 \times P_{\text{nenn}}$$

P_{halte} [W] Coil capacity on power reduction

$$P_{\text{halte}} = \left(\frac{U_{\text{halte}}}{U_{\text{nenn}}} \right)^2 \times P_{\text{nenn}}$$

$t_{\text{über}}$ [s] Overexcitation time

t_{halte} [s] Time of operation with power reduction

t_{aus} [s] Time without voltage

t_{ges} [s] Total time ($t_{\text{über}} + t_{\text{halte}} + t_{\text{aus}}$)

$U_{\text{über}}$ [V] Overexcitation voltage (bridge voltage)

U_{halte} [V] Holding voltage (half-wave voltage)

U_{nenn} [V] Coil nominal voltage

Time Diagram:

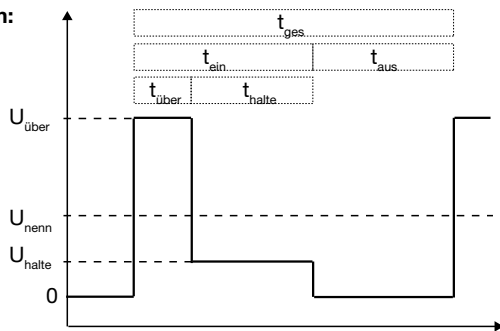

For brakes, which do not require overexcitation, the holding voltage U_{halte} may be lower than the nominal voltage U_{nenn} , e.g. on power reduction to reduce the coil temperature.

Diagram: Brake separation time t_2 dependent on spring configuration

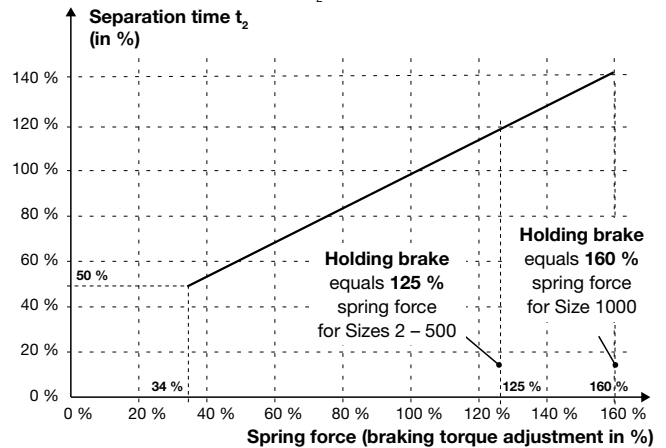

Magnetic Field Removal

• AC-side switching

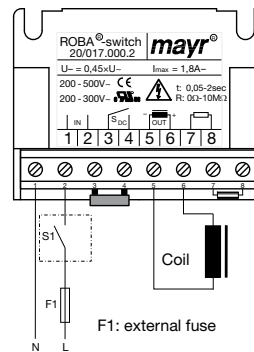

The power circuit is interrupted before the rectifier. The magnetic field slowly reduces. This delays the rise in braking torque.

When switching times are not important, please switch AC-side, as no protective measures are necessary for coil and switching contacts.

AC-side switching means **low-noise switching**; however, the brake engagement time is longer (approx. 6 – 10 times longer than with DC-side switch-off). Use for non-critical braking times.

• DC-side switching

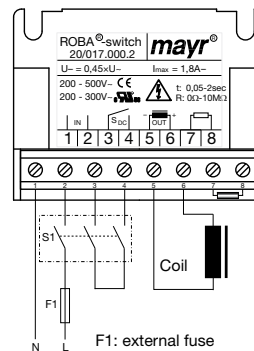

The power circuit is interrupted between the rectifier and the coil as well as mains-side. The magnetic field is removed very quickly, resulting in a rapid rise in braking torque.

When switching DC-side, high voltage peaks are produced in the coil, which lead to wear on the contacts from sparks and to destruction of the insulation.

DC-side switching means **short brake engagement times (e.g. for EMERGENCY STOP operation)**. However, this produces louder switching noises.

• Protective Circuit

When using DC-side switching, the coil must be protected by a suitable protective circuit according to VDE 0580, which is integrated in *mayr*® rectifiers. To protect the switching contact from consumption when using DC-side switching, additional protective measures may be necessary (e.g. series connection of switching contacts). The switching contacts used should have a minimum contact opening of 3 mm and should be suitable for inductive load switching. Please make sure on selection that the rated voltage and the rated operation current are sufficient. Depending on the application, the switching contact can also be protected by other protective circuits (e.g. *mayr*® spark quenching units), although this may of course then alter the switching times.

Electrical Accessories (more information: www.mayr-gleichrichter.de)

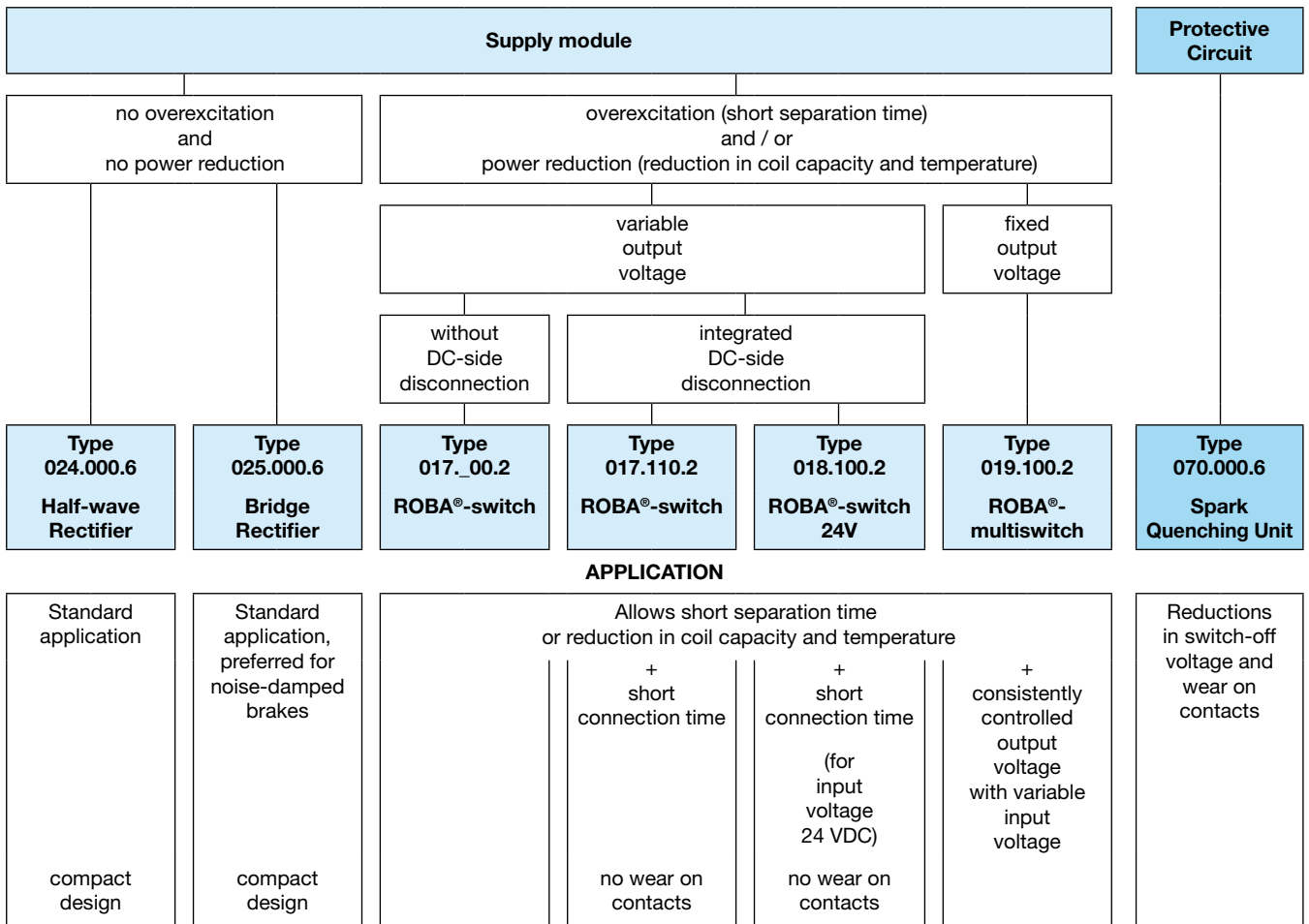

Example 1

Available: network voltage 230 VAC
 Wanted: short separation time (overexcitation)
 Required: supply module / coil nominal voltage

Solution:

- Supply modules available for selection: Type 017._00.2 (in Example below), Type 017.110.2 or Type 019.100.2
- Coil nominal voltage: 104 VDC

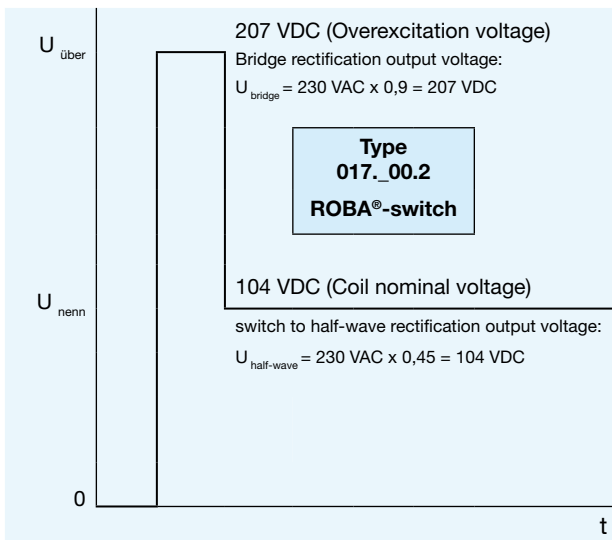

Example 2

Available: network voltage 400 VAC
 Wanted: short separation time (overexcitation) and low coil temperature (power reduction)
 Required: supply module / coil nominal voltage

Solution:

- Supply modules available for selection: Type 017._00.2 (in Example below), Type 017.110.2 or Type 019.100.2
- Coil nominal voltage: 207 VDC

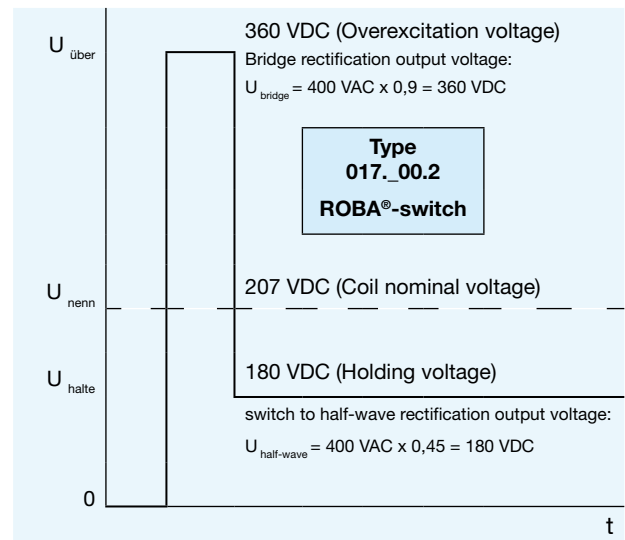

Half-wave Rectifiers and Bridge Rectifiers Type 02_ .000.6



Application

Rectifiers are used to connect DC units to alternating voltage supplies, for example electromagnetic brakes and clutches (ROBA-stop[®], ROBA-quick[®], ROBATIC[®]), electromagnets, electrovalves, contactors, switch-on safe DC motors, etc.

Function

The AC input voltage (VAC) is rectified (VDC) in order to operate DC voltage units. Also, voltage peaks, which occur when switching off inductive loads and which may cause damage to insulation and contacts, are limited and the contact load reduced.



Electrical Connection (Terminals)

- 1 + 2 Input voltage
- 3 + 4 Connection for an external switch for DC-side switching
- 5 + 6 Coil
- 7 - 10 Free nc terminals (only for Size 2)

Order Number

___ / 0 2 ___ . 0 0 0 . 6

| | |
|---------------------------------|---|
| ▲ | ▲ |
| Sizes 1 up to 4 | 4 Half-wave rectifier 5 Bridge rectifier |

Dimensions (mm)

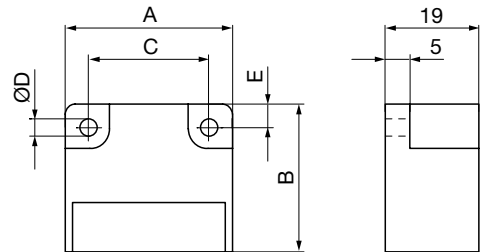

| Size | A | B | C | ØD | E |
|------|----|----|----|-----|-----|
| 1 | 34 | 30 | 25 | 3,5 | 4,5 |
| 2 | 54 | 30 | 44 | 4,5 | 5,0 |
| 3/4 | 64 | 30 | 54 | 4,5 | 5,0 |

Accessories: Mounting bracket set for 35 mm rail acc. EN 60715: Article No. 1803201

Technical Data

| | | | Bridge rectifier | | Half-wave rectifier | | | | |
|--|--|-------------------------------------|--|--------------|---------------------|--------------|--------------|--------------|------|
| Calculation output voltage | | | VDC = VAC x 0,9 | | VDC = VAC x 0,45 | | | | |
| Type | | | 1/025 | 2/025 | 1/024 | 2/024 | 3/024 | 4/024 | |
| Max. input voltage | ± 10 % | U _{AC} [VAC] | 230 | 230 | 400 | 400 | 500 | 600 | |
| Max. output voltage | | U _{DC} [VDC] | 207 | 207 | 180 | 180 | 225 | 270 | |
| Output current at | ≤ 50 °C | I _{RMS} [A] | 2,5 | 2,5 | 3,0 | 4,0 | 4,0 | 4,0 | |
| | max. 85 °C | I _{RMS} [A] | 1,7 | 1,7 | 1,8 | 2,4 | 2,4 | 2,4 | |
| Max. coil nominal capacity at | U _{AC} = 115 VAC | ≤ 50 °C | P _{nenn} [W] | 260 | 260 | - | - | - | - |
| | | up to 85 °C | P _{nenn} [W] | 177 | 177 | - | - | - | - |
| | U _{AC} = 230 VAC | ≤ 50 °C | P _{nenn} [W] | 517 | 517 | 312 | 416 | 416 | 416 |
| | | up to 85 °C | P _{nenn} [W] | 352 | 352 | 187 | 250 | 250 | 250 |
| | U _{AC} = 400 VAC | ≤ 50 °C | P _{nenn} [W] | - | - | 540 | 720 | 720 | 720 |
| | | up to 85 °C | P _{nenn} [W] | - | - | 324 | 432 | 432 | 432 |
| | U _{AC} = 500 VAC | ≤ 50 °C | P _{nenn} [W] | - | - | - | - | 900 | 900 |
| | | up to 85 °C | P _{nenn} [W] | - | - | - | - | 540 | 540 |
| | U _{AC} = 600 VAC | ≤ 50 °C | P _{nenn} [W] | - | - | - | - | - | 1080 |
| | | up to 85 °C | P _{nenn} [W] | - | - | - | - | - | 648 |
| | Peak reverse voltage | | [V] | 1600 | 1600 | 2000 | 1600 | 2000 | 2000 |
| | Rated insulation voltage | | U _{RMS} [V _{RMS}] | 320 | 320 | 500 | 500 | 630 | 630 |
| Pollution degree (insulation coordination) | | | 1 | 1 | 1 | 1 | 1 | 1 | |
| Device fuses | | | To be included in the input voltage line. | | | | | | |
| Recommended microfuse switching capacity H | The microfuse corresponds to the max. possible connection capacity. If fuses are used corresponding to the actual capacities, the permitted limit integral I ² t must be observed on selection. | | FF 3,15 A | FF 3,15 A | FF 4 A | FF 5 A | FF 5 A | FF 5 A | |
| Permitted limit integral | | I ² t [A ² s] | 40 | 40 | 50 | 100 | 50 | 50 | |
| Protection | | | IP65 components, encapsulated / IP20 terminals | | | | | | |
| Terminals | | | Cross-section 0,14 - 1,5 mm ² (AWG 26-14) | | | | | | |
| Ambient temperature | | [°C] | - 25 up to + 85 | | | | | | |
| Storage temperature | | [°C] | - 40 up to + 85 | | | | | | |
| Conformity markings | | | UL, CE | UL, CE | UL, CE | UL, CE | UL, CE | CE | |
| Installation conditions | | | The installation position can be user-defined. Please ensure sufficient heat dissipation and air convection! Do not install near to sources of intense heat! | | | | | | |

ROBA®-switch Type 017._00.2

Application

ROBA®-switch fast acting rectifiers are used to connect DC consumers to alternating voltage supplies, for example electromagnetic brakes and couplings (ROBA-stop®, ROBA®-quick, ROBATIC®) as well as electromagnets and electrovalves etc.

Fast acting rectifier ROBA®-switch 017._00.2

- Consumer operation with overexcitation or power reduction
- Input voltage: 100 - 500 VAC
- Maximum output current I_{RMS} : 3 A at 250 VAC
- UL-approved

Function

The ROBA®-switch units are used for operation at an input voltage of between 100 and 500 VAC, dependent on the Size. They can switch internally from bridge rectification output voltage to half-wave rectification output voltage. The bridge rectification time can be modified from 0,05 to 2 seconds by exchanging the external resistor (R_{ext}).









Electrical Connection (Terminals)

- 1 + 2 Input voltage (fitted protective varistor)
- 3 + 4 Connection for external contact for DC-side switch-off
- 5 + 6 Output voltage (fitted protective varistor)
- 7 + 8 R_{ext} for bridge rectification time adjustment

Technical Data

| | |
|-----------------------------|---|
| Input voltage | see Table 1 |
| Output voltage | see Table 1 |
| Protection | IP65 components, IP20 terminals, IP10 R_{ext} |
| Terminal nom. cross-section | 1,5 mm ² , (AWG 22-14) |
| Ambient temperature | -25 °C up to +70 °C |
| Storage temperature | -40 °C up to +70 °C |

ROBA®-switch Sizes, Table 1

| | | Size | | | |
|-------------------------|-----------------------|---|---|---|---|
| | | Type 017.000.2 | | Type 017.100.2 | |
| | | 10 | 20 | 10 | 20 |
| Input voltage ± 10 % | U_{AC} [VAC] | 100-250 | 200-500 | 100-250 | 200-500 |
| Output voltage | U_{bridge} [VDC] | 90-225 | 180-450 | 90-225 | 180-450 |
| | $U_{half-wave}$ [VDC] | 45-113 | 90-225 | 45-113 | 90-225 |
| Output current | at ≤ 45 °C | | | | |
| | I_{RMS} [A] | 2,0 | 1,8 | 3,0 | 2,0 |
| at max. 70 °C | I_{RMS} [A] | 1,0 | 0,9 | 1,5 | 1,0 |
| Comformity markings | |  |  |  |  |
| | |  |  |  |  |

Order Number

| | |
|---------------------------|-------------|
| ___ / 0 1 7 . ___ 0 0 . 2 | |
| ▲ | ▲ |
| Size | UL-approved |
| 10 | 0 to 300 V |
| 20 | 1 to 500 V |



Dimensions (mm)

Type 017.000.2

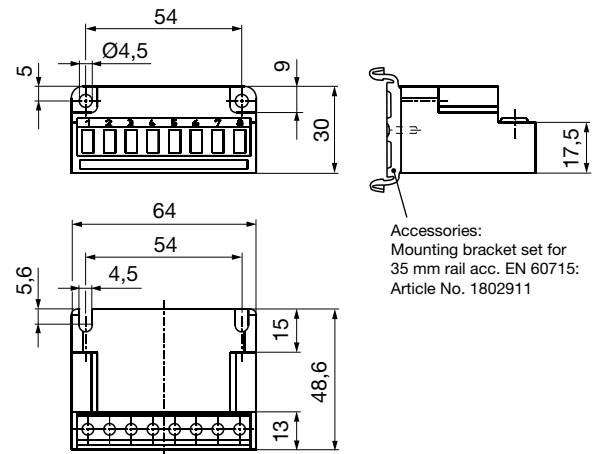

Accessories:
Mounting bracket set for
35 mm rail acc. EN 60715:
Article No. 1802911

Type 017.100.2

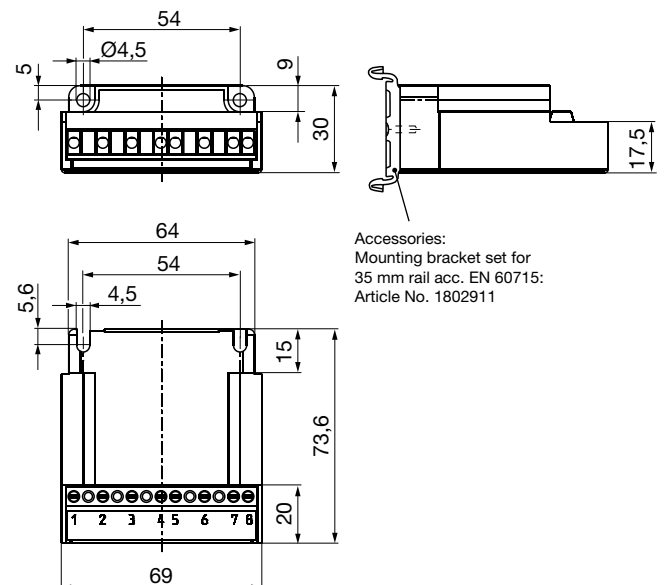

Accessories:
Mounting bracket set for
35 mm rail acc. EN 60715:
Article No. 1802911

ROBA[®]-switch Type 017.110.2

Application

ROBA[®]-switch fast acting rectifiers are used to connect DC consumers to alternating voltage supplies, for example electromagnetic brakes and clutches (ROBA-stop[®], ROBA[®]-quick, ROBATIC[®]), lectromagnets, electrovalves, etc.

Fast acting rectifier ROBA[®]-switch 017.110.2

- Consumer operation with overexcitation or power reduction
- Integrated DC-side disconnection (shorter connection time t_c)
- Input voltage: 100 – 500 VAC
- Max. output current I_{RMS} : 1,5 A
- UL-approved



The ROBA[®]-switch units with integrated DC-side disconnection are not suitable for being the only safety disconnections in applications!

Function

The ROBA[®]-switch units are used for operation at an input voltage of between 100 and 500 VAC, depending on the Size. They can switch internally from bridge rectification output voltage to half-wave rectification output voltage. The bridge rectification time can be modified from 0,05 to 2 seconds by exchanging the external resistor (R_{ext}).

The ROBA[®]-switch units also have an integrated DC-side disconnection. In contrast to the conventional DC-side disconnection, no further protective measures or external components are necessary. The DC-side disconnection is standard-activated (terminals 3 and 4 are not wired), resulting in short electromagnetic consumer switching times.

The integrated DC-side disconnection is deactivated by fitting a bridge between the terminals 3 and 4. The coil is deenergised via the free wheeling diode. This has the advantages of softer braking and a lower switching noise. However, the switching times increase (taking approx. 6 - 10 times longer).

Electrical Connection (Terminals)

- 1 + 2 Input voltage (fitted protective varistor)
- 3 + 4 Switching between DC- and AC-side disconnection
- 5 + 6 Output voltage (fitted protective varistor)
- 7 + 8 R_{ext} for bridge rectification time adjustment

Technical Data

| | |
|-----------------------------|---|
| Input voltage | see Table 1 |
| Output voltage | see Table 1 |
| Protection | IP65 components, IP20 terminals IP10 R_{ext} |
| Terminal nom. cross-section | 1,5 mm ² , (AWG 22-14) |
| Ambient temperature | -25 °C up to +70 °C |
| Storage temperature | -40 °C up to +70 °C |

Dimensions (mm)

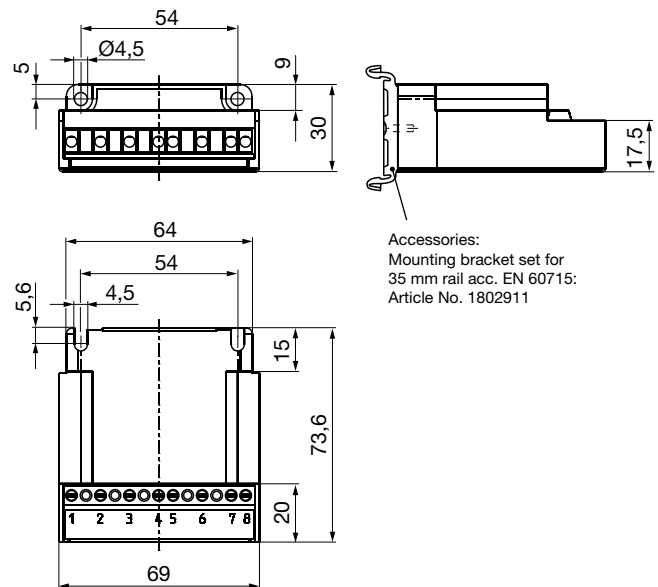

Accessories:
Mounting bracket set for
35 mm rail acc. EN 60715:
Article No. 1802911

ROBA[®]-switch Sizes, Table 1

| | | | Size | | |
|-----------------------------|------------------------|--------------|---------------------------|---------------------------|-----------|
| | | | 10 | 20 | |
| Input voltage $\pm 10\%$ | U_{AC} | [VAC] | 100 – 250 | 200 – 500 | |
| | Output voltage | U_{bridge} | [VDC] | 90 – 225 | 180 – 450 |
| $U_{half-wave}$ | | [VDC] | 45 – 113 | 90 – 225 | |
| Output current | at $\leq 45\text{ °C}$ | I_{RMS} | [A] | 1,5 | 1,5 |
| | at max. 70 °C | I_{RMS} | [A] | 0,75 | 0,75 |
| Conformity markings | | | UL US CE | UL US CE | |

Order Number

— / 0 1 7 . 1 1 0 . 2



Size
10
20

ROBA®-multiswitch Type 019.100.2



Application

ROBA®-multiswitch fast acting rectifiers are used to connect DC units to alternating voltage supplies, for example electromagnetic brakes and clutches (ROBA-stop®, ROBA®-quick, ROBATIC®), electromagnets, electrovalves etc.

Fast acting rectifier ROBA®-multiswitch 019.100.2

- Consistently controlled output voltage in the entire input voltage range.
- Consumer operation with overexcitation or power reduction
- Input voltage: 100 – 500 VAC
- Max. output current I_{RMS} : 2 A



ROBA®-multiswitch units are not suitable for all applications, e.g. use of the ROBA®-multiswitch when operating noise-damped brakes is not possible without taking additional measures. The product's suitability should be checked before use.

Function

The ROBA®-multiswitch units are (dependent on Size) used for an input voltage of between 100 and 500. After switch-on, they emit the rectified bridge voltage for 50 ms and then control the 90 or 180 VDC overexcitation voltages. After the overexcitation period, they control the 52 or 104 VDC holding voltages. The overexcitation period can be adjusted via a DIP-switch to 150 ms, 450 ms, 1 s, 1,5 s and 2 s.

Electrical Connection (Terminals)

- 1 + 2 Input voltage (fitted protective varistor)
- 3 + 4 Connection for external contact for DC-side switch-off
- 5 + 6 Output voltage (fitted protective varistor)

Technical Data

| | |
|-----------------------------|-----------------------------------|
| Input voltage | see Table 1 |
| Output voltage | see Table 1 |
| Protection | IP65 components, IP20 terminals |
| Terminal nom. cross-section | 1,5 mm ² , (AWG 22-14) |
| Ambient temperature | -25 °C up to +70 °C |
| Storage temperature | -40 °C up to +70 °C |



Dimensions (mm)

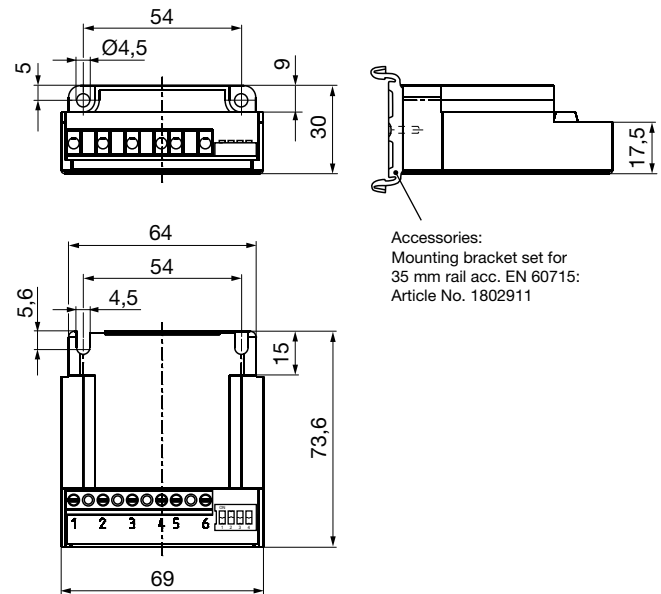



Order Number

___ / 0 1 9 . 1 0 0 . 2



Size
10
20

ROBA®-multiswitch Sizes, Table 1

| | | | | Size | |
|---------------------|--------------------------|--------------------------|------|---|---|
| | | | | 10 | 20 |
| Input voltage | $\pm 10\%$ acc. EN 50160 | U_i [VAC] | | 100 – 275 | 200 – 500 |
| | Frequency | | [Hz] | 50 – 60 | 50 – 60 |
| Output voltage | $\pm 10\%$ | $U_{\text{über}}$ [VDC] | | 90 | 180 |
| | $\pm 10\%$ | U_{halte} [VDC] | | 52 | 104 |
| Output current | at $\leq 45\text{ °C}$ | I_{RMS} [A] | | 2,0 | 2,0 |
| | at max. 70 °C | I_{RMS} [A] | | 1,0 | 1,0 |
| Conformity markings | | | |  |  |

Spark Quenching Unit Type 070.000.6



Application

Reduces spark production on the switching contacts occurring during VDC inductive load switching.

- Voltage limitation according to VDE0580 2000-07, Item 4.6.
- Reduction of EMC-disturbance by voltage rise limitation, suppression of switching sparks.
- Reduction of brake engagement times by a factor of 2 – 4 compared to free-wheeling diodes.

Function

The spark quenching unit will absorb voltage peaks resulting from inductive load switching, which can cause damage to insulation and contacts. It limits these to 70 V and reduces the contact load. Switching products with a contact opening distance of > 3 mm are suitable for this purpose.

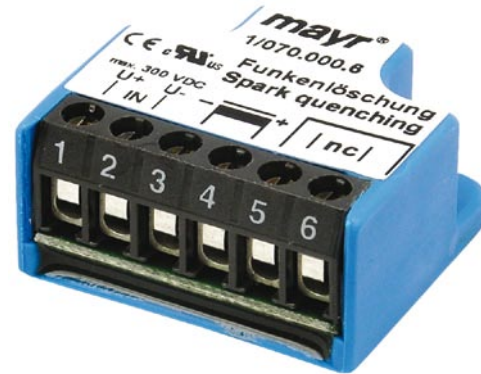

Electrical Connection (Terminals)

- 1 (+) Input voltage
- 2 (-) Input voltage
- 3 (-) Coil
- 4 (+) Coil
- 5 Free nc terminal
- 6 Free nc terminal

Technical Data

| | |
|------------------------------------|---|
| Input voltage | max. 300 VDC, max. 615 V _{peak} (rectified voltage 400 VAC, 50/60 Hz) |
| Switch-off energy | max. 9J/2 ms |
| Power dissipation | max. 0,1 Watt |
| Max. voltage nc terminals | 250 V |
| Protection | IP65 / IP20 terminals |
| Ambient temperature | -25 °C up to +85 °C |
| Storage temperature | -40 °C up to +85 °C |
| Max. conductor connection diameter | 2,5 mm ² / AWG 26-12 |
| Max. terminal tightening torque | 0,5 Nm |

Dimensions (mm)

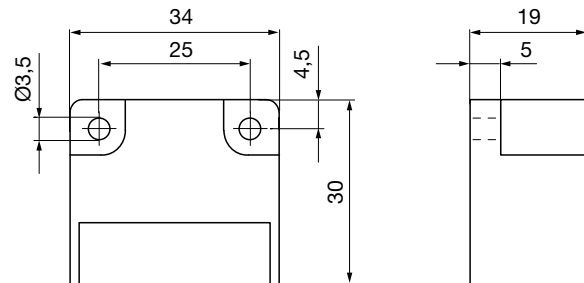

Accessories

Mounting bracket set for 35 mm rail acc. EN 60715:
Article No. 1803201

Order Number

— / 0 7 0 . 0 0 0 . 6



Size
1

ROBA-stop®-M – Guidelines



Guidelines on the Declaration of Conformity: A conformity evaluation has been carried out for the product (electromagnetic safety brake) according to the EC Low Voltage Directive 2006/95/EC. The conformity evaluation is set out in writing in a separate document and can be requested if required.

Guidelines on the EMC Directive (2004/108/EC): The product cannot be operated independently according to the EMC Directive. Due to their passive state, brakes are also non-critical equipment according to the EMC. Only after integration of the product into an overall system can this be evaluated in terms of the EMC. For electronic equipment, the evaluation has been verified for the individual product in laboratory conditions but not in the overall system.

Guidelines on the Machinery Directive (2006/42/EC): The product is a component for installation into machines according to the Machinery Directive 2006/42/EC. The brakes can fulfil the specifications for safety-related applications in coordination with other elements. The type and scope of the required measures result from the machine risk analysis. The brake then becomes a machine component and the machine manufacturer assesses the conformity of the safety unit to the directive. It is forbidden to put the product into initial operation until it has been ensured that the machine accords with the stipulations in the directive.

Guidelines on the ATEX Directive: Without a conformity evaluation, this product is not suitable for use in areas where there is a high danger of explosion. In order to use this product in areas where there is a danger of explosion, classification and marking according to the directive 94/9/EC must be carried out.

Safety Guidelines

Brakes may generate, among other things, the following risks:



During the risk assessment, the dangers involved must be evaluated and removed by taking appropriate protective measures. **To prevent injury or damage, only professionals and specialists should work on the devices.** They must be familiar with the dimensioning, transport, installation, initial operation, maintenance and disposal according to the relevant standards and regulations.

Application Conditions



The catalogue values are guideline values which have been determined in test facilities. It may be necessary to carry out your own tests for the intended application.

When dimensioning the brakes, please remember that installation situations, braking torque fluctuations, permitted friction work, run-in behaviour and wear as well as general ambient conditions can all affect the given values. These factors should therefore be carefully assessed, and alignments made accordingly.

- Mounting dimensions and connecting dimensions must be adjusted according to the size of the brake at the place of installation.
- The magnetic coils are designed for a relative duty cycle of 100 %, if no other values are stated.
- The braking torque is dependent on the present run-in condition of the brakes
- The brakes are only designed for dry running. The torque is lost if the friction surfaces come into contact with oil, grease, water or similar substances, such as other foreign substances.
- Manufacturer-side corrosion protection of the metallic surfaces.
- The rotors may rust up and block in corrosive ambient conditions and/or after long periods of storage.

Ambient Temperature – 20 °C up to + 40 °C

Protection

(mechanical) IP54: When installed, dust-proof and protected against contact as well as against water spray coming from any direction (dependent on the customer-side attachment).

(electrical) IP54: Dust-proof and protected against contact as well as against splashing water from all directions.

IP65 (Type 891..._1): Dust-proof and protected against contact as well as against jet water from a nozzle coming from any direction.

Earthing Connection

The brake is designed for Protection Class I. This protection covers not only the basic insulation, but also the connection of all conductive parts to the PE conductor on the fixed installation. Please carry out a standardized inspection of the PE conductor connections to all contactable metal parts!

Intended Use

mayr® brakes have been developed, manufactured and tested in compliance with the VDE 0580 standard, in accordance with the EU Low Voltage Directive. During installation, operation and maintenance of the product, the standard requirements must be observed. mayr® brakes are for use in machines and systems and must only be used in the situations for which they are ordered and confirmed. Using them for any other purpose is not allowed!

Guidelines for Electromagnetic Compatibility (EMC)

In accordance with the EMC Directives 2004/108/EC, the individual components produce no emissions. However, functional components e.g. mains-side energisation of the brakes with rectifiers, phase demodulators, ROBA®-switch devices or similar controls can produce disturbance which lies above the allowed limit values. For this reason it is important to read the Installation and Operational Instructions very carefully and to keep to the EMC Directives.

Regulations, Standards and Directives Used

| | |
|-----------------------|--|
| VDE 0580 | Electromagnetic devices and components, general directives |
| 2006/95/EC | Low voltage directive |
| CSA C22.2 No. 14-2010 | Industrial Control Equipment |
| UL 508 (Edition 17) | Industrial Control Equipment |
| EN ISO 12100 | Safety of machinery - General principles for design - Risk assessment and risk reduction |
| EN 61000-6-4 | Interference emission |
| EN 61000-6-2 | Interference immunity |
| EN 60204-1 | Electrical machine equipment |

Liability

- The information, guidelines and technical data in these documents were up to date at the time of printing. Demands on previously delivered brakes are not valid.
- Liability for damage and operational malfunction will not be taken when
 - the Installation and Operational Instructions are ignored or neglected.
 - the brakes are used inappropriately.
 - the brakes are modified.
 - the brakes are worked on unprofessionally.
 - the brakes are handled or operated incorrectly.

Guarantee

- The guarantee conditions correspond with the Chr. Mayr GmbH + Co. KG sales and delivery conditions.
- Mistakes or deficiencies are to be reported to mayr® at once!

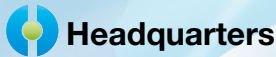

Chr. Mayr GmbH + Co. KG
Eichenstrasse 1, D-87665 Mauerstetten
Tel.: +49 83 41/8 04-0, Fax: +49 83 41/80 44 21
www.mayr.com, E-Mail: info@mayr.com



your reliable partner

Service Germany

Baden-Württemberg

Esslinger Straße 7
 70771 Leinfelden-Echterdingen
 Tel.: 07 11/45 96 01 0
 Fax: 07 11/45 96 01 10

Bavaria

Eichenstrasse 1
 87665 Mauerstetten
 Tel.: 0 83 41/80 41 04
 Fax: 0 83 41/80 44 23

Chemnitz

Bornaer Straße 205
 09114 Chemnitz
 Tel.: 03 71/4 74 18 96
 Fax: 03 71/4 74 18 95

Franken

Unterer Markt 9
 91217 Hersbruck
 Tel.: 0 91 51/81 48 64
 Fax: 0 91 51/81 62 45

Hagen

Im Langenstück 6
 58093 Hagen
 Tel.: 0 23 31/78 03 0
 Fax: 0 23 31/78 03 25

Kamen

Lünener Strasse 211
 59174 Kamen
 Tel.: 0 23 07/23 63 85
 Fax: 0 23 07/24 26 74

North

Schiefer Brink 8
 32699 Extertal
 Tel.: 0 57 54/9 20 77
 Fax: 0 57 54/9 20 78

Rhine-Main

Hans-Böckler-Straße 6
 64823 Groß-Umstadt
 Tel.: 0 60 78/7 82 53 37
 Fax: 0 60 78/9 30 08 00

Branch office

China

Mayr Zhangjiagang
 Power Transmission Co., Ltd.
 Changxing Road No. 16,
 215600 Zhangjiagang
 Tel.: 05 12/58 91-75 65
 Fax: 05 12/58 91-75 66
 info@mayr-ptc.cn

Great Britain

Mayr Transmissions Ltd.
 Valley Road, Business Park
 Keighley, BD21 4LZ
 West Yorkshire
 Tel.: 0 15 35/66 39 00
 Fax: 0 15 35/66 32 61
 sales@mayr.co.uk

France

Mayr France S.A.
 Z.A.L. du Minopole
 Rue Nungesser et Coli
 62160 Bully-Les-Mines
 Tel.: 03.21.72.91.91
 Fax: 03.21.29.71.77
 contact@mayr.fr

Italy

Mayr Italia S.r.l.
 Viale Veneto, 3
 35020 Saonara (PD)
 Tel.: 0498/79 10 20
 Fax: 0498/79 10 22
 info@mayr-italia.it

Singapore

Mayr Transmission (S) PTE Ltd.
 No. 8 Boon Lay Way Unit 03-06,
 TradeHub 21
 Singapore 609964
 Tel.: 00 65/65 60 12 30
 Fax: 00 65/65 60 10 00
 info@mayr.com.sg

Switzerland

Mayr Kupplungen AG
 Tobelackerstrasse 11
 8212 Neuhausen am Rheinfall
 Tel.: 0 52/6 74 08 70
 Fax: 0 52/6 74 08 75
 info@mayr.ch

USA

Mayr Corporation
 4 North Street
 Waldwick
 NJ 07463
 Tel.: 2 01/4 45-72 10
 Fax: 2 01/4 45-80 19
 info@mayrcorp.com

Representatives

Australia

Regal Beloit Australia Pty Ltd.
 19 Corporate Ave
 03178 Rowville, Victoria
 Australien
 Tel.: 0 3/92 37 40 00
 Fax: 0 3/92 37 40 80
 salesAUvic@regalbeloit.com

India

National Engineering
 Company (NENCO)
 J-225, M.I.D.C.
 Bhosari Pune 411026
 Tel.: 0 20/27 13 00 29
 Fax: 0 20/27 13 02 29
 nenco@nenco.org

Japan

MATSUI Corporation
 2-4-7 Azabudai
 Minato-ku
 Tokyo 106-8641
 Tel.: 03/35 86-41 41
 Fax: 03/32 24 24 10
 k.goto@matsui-corp.co.jp

Netherlands

Groneman BV
 Amarilstraat 11
 7554 TV Hengelo OV
 Tel.: 074/2 55 11 40
 Fax: 074/2 55 11 09
 aandrijftechnik@groneman.nl

Poland

Wamex Sp. z o.o.
 ul. Pozaryskiego, 28
 04-703 Warszawa
 Tel.: 0 22/6 15 90 80
 Fax: 0 22/8 15 61 80
 wamex@wamex.com.pl

South Korea

Mayr Korea Co. Ltd.
 Room No.1002, 10th floor,
 Nex Zone, SK TECHNOPARK,
 77-1, SungSan-Dong,
 SungSan-Gu, Changwon, Korea
 Tel.: 0 55/2 62-40 24
 Fax: 0 55/2 62-40 25
 info@mayrkorea.com

Taiwan

German Tech Auto Co., Ltd.
 No. 28, Fenggong Zhong Road,
 Shengang Dist.,
 Taichung City 429, Taiwan R.O.C.
 Tel.: 04/25 15 05 66
 Fax: 04/25 15 24 13
 abby@zfgta.com.tw

Czech Republic

BMC BALTAS s. r. o.
 Hvězdoslavova 29 b
 62700 Brno
 Tel.: 05/45 22 60 47
 Fax: 05/45 22 60 48
 info@bmcaltas.cz

More representatives:

Austria, Belgium, Brazil, Canada, Denmark, Finland, Greece, Hongkong, Hungary, Indonesia, Israel, Luxembourg, Malaysia, New Zealand, Norway, Philippines, Romania, Russia, Slovakia, Slovenia, South Africa, Spain, Sweden, Thailand, Turkey

You can find the complete address for the representative responsible for your area under www.mayr.com in the internet.